

Donaldson
Torit®



BIN VENT DUST COLLECTOR

MODELS TBV-2, TBV-4, TBV-6

Cartridge filtration technology that adds economic value and recovers valuable dust.

- Efficient, compact design for applications involving silos, storage bins, or conveyor transfer points
- Available as plenum-mounted and insertable cabinets to keep the profile low
- Units are easily installed on bins or silos, eliminating ductwork and reducing installation expenses
- Standard Ultra-Web® cartridge filters, with fine fiber technology, provide higher filtration efficiency and longer filter life
- MERV* 15 filtration efficiency per ASHRAE 52.2-2007
- Choice of filter cartridges provide high filtration efficiency for a wide variety of applications

Designed for easy filter service and maintenance — no tools required.

- Easy filter removal and replacement from clean air side makes it unnecessary to enter the silo or storage container
- Continuous-duty, on-demand pulse cleaning provides uninterrupted service and keeps filters clean for a long time

ULTRA-WEB®
High Efficiency **Fine Fiber Filters** Built to Last



TBV-4 with Plenum

* The Minimum Efficiency Reporting Value (MERV) of this filter cartridge has been determined through independent laboratory testing using ASHRAE 52.2 (2007) test standards. The MERV rating was determined at a face velocity of 118 feet (36.0 meters) per minute and loading up to four inches (101.6 millimeters) water gauge. Actual efficiency of any filter cartridge will vary according to the specific application parameters. Dust concentration, airflow, particle characteristics, and pulse cleaning methods all affect filtration efficiency.

DIMENSIONS & SPECIFICATIONS

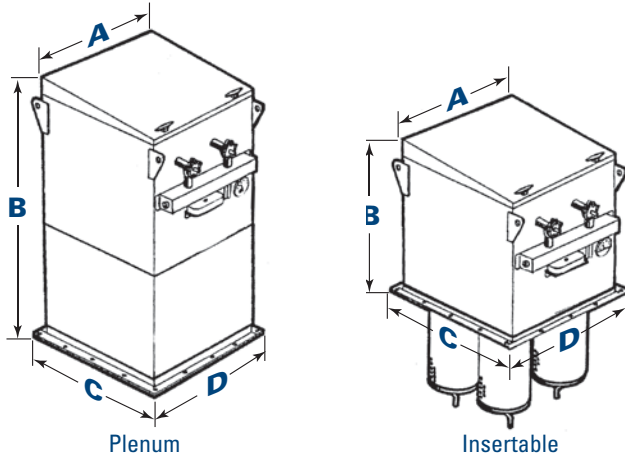

Models	Filter Area						No. of Cartridges	No. of Valves
	Ultra-Web		Fibra-Web Ultra-Tek		Torit-Tex			
	ft ²	m ²	ft ²	m ²	ft ²	m ²		
TBV-2	452	42.0	220	20.4	100	9.3	2	2
TBV-4	904	84.0	440	40.9	200	18.6	4	2
TBV-6	1,356	126.0	660	61.3	300	27.9	6	3

Models	Dimensions										Shipping Weight			
	A		B				C		D		Plenum		Insertable	
			Plenum		Insertable						Plenum		Insertable	
	in	mm	in	mm	in	mm	in	mm	in	mm	lb	kg	lb	kg
TBV-2	34.6	878.8	53.6	1361.4	33.1	840.7	24.2	614.7	37.5	952.5	441	200.0	377	171.0
TBV-4	34.6	878.8	54.6	1386.8	34.1	866.1	35.4	899.2	37.5	952.5	702	318.4	627	284.4
TBV-6	51.9	1318.3	54.6	1386.8	34.1	866.1	35.4	899.2	54.7	1389.4	792	359.2	702	318.4

STANDARD FEATURES & AVAILABLE OPTIONS

STANDARD

- Ultra-Web® cartridge
- NEMA 4 enclosure
- 10-year warranty

OPTIONAL

- Insertable or plenum style
- Cartridges
 - Ultra-Web® FR
 - Ultra-Tek®
 - Fibra-Web® & Fibra-Web FR
 - Torit-Tex™
- Weatherhood
 - 1, 2, 3, and 5 hp fans
- Dampers
- Chamber silencers
- Magnehelic®** gauge
- Photohelic®** gauge
- NEMA 9 enclosure
- Hostile environment coating

* Magnehelic and Photohelic are registered trademarks of Dwyer Instruments, Inc.

Significantly improve the performance of your collector with genuine Donaldson Torit replacement filters and parts.

Important Notice

Many factors beyond the control of Donaldson can affect the use and performance of Donaldson products in a particular application, including the conditions under which the product is used. Since these factors are uniquely within the user's knowledge and control, it is essential the user evaluate the products to determine whether the product is fit for the particular purpose and suitable for the user's application. All products, product specifications, availability and data are subject to change without notice, and may vary by region or country.

