

LOCAL EXTRACTOR

MiniTEX 1100, 1500

**Flexible, telescopic
local extractor with the
market's lowest pressure drop.**

The MOVEX local extractor MiniTEX, with lengths of 1.1 m and 1.5 m, is a telescopic local extractor e.g. for laboratories that require a compact extractor with a very low pressure drop.

MiniTEX is equipped with gas springs to balance the weight of the arm. Its adjustable telescopic function, moveable angle joint and 360° swivel, along with the flexible suction unit, gives a local extractor that is both easily moved and has stable positioning. MOVEX always designs its local extractors with external support arms, which ensures a natural and linear airflow. This gives a low pressure drop and a low risk of blockage.

With the special telescopic function, the MiniTEX has a much lower pressure drop than conventional suction arms. Therefore, it is exceptionally suitable when there is a need for a low pressure drop in the extraction system. The MiniTEX can also be equipped with different hoods, which further increase the extraction efficiency.

The joints and telescopic function can be simply adjusted from the outside. The smooth tubes ease internal cleaning of the extraction duct. The arm is supplied complete with an airtight damper. The MOVEX MiniTEX is available in designs for ceiling- or wall mounting.



Also included in the Movex range are fans, accessories, automatic controls and filters suitable for the local extractor

MOVEX[®]
L O C A L E X T R A C T O R

Pure Advantages

The market's lowest pressure drop

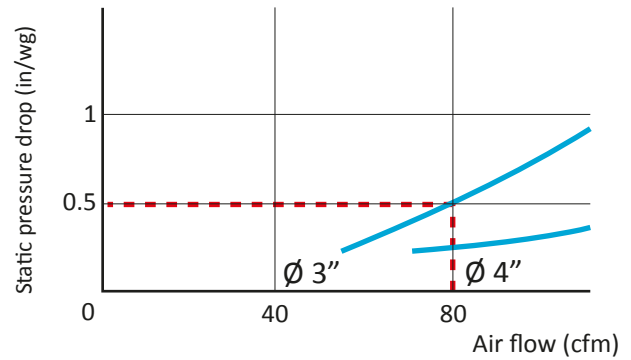

The low pressure drop gives many benefits

The MiniTEX has a linear airflow, without internal components to obstruct the air stream. At the same time, the telescopic function permits a relatively high air velocity in the suction nozzle.

For most types of laboratories, a diameter of Ø3" and an airflow of 80 cfm is recommended. This airflow provides a sufficiently large air volume to evacuate the air pollutants that arise. MiniTEX, with Ø3", provides a static pressure drop of only 0.5 in/wg at 80 cfm, while at the same time the nozzle air velocity is nearly 33 ft/s.

These characteristics give several benefits.

- It is easy to use the MiniTEX in the same ventilation system, for example, as a fume cupboard that also has a very low pressure drop.
- The high nozzle air velocity provides effective capture of pollutants and it is not easily influenced by other disturbing air currents in the area.
- The low pressure drop minimises the risk of noise problems.

Ideal for low ceilings



MiniTEX is ideal for low ceilings and low hanging light fittings

The telescopic function, with just one bendable joint, means the extractor is never at risk of collision with low hanging light fittings or low suspended ceilings.

Neat and stable brackets

MiniTEX is supplied with a stable grip in anodised aluminium with a high finish to obtain a good, functioning extraction.

MTI-125 Ceiling bracket can be fitted with sleeves both below and above a false ceiling, in the latter case preferably together with MTI CT-125.

MVK-125 Wall bracket is always included in models with designation MXV.

MTF-125 Ceiling bracket for fitting through e.g. roof beams. Fixing plate is adjustable along whole length of aluminium tube, if required, aluminium profile can be cut to fit.



Range and recommended mounting height for MX 1100-75 and MX 1100-100

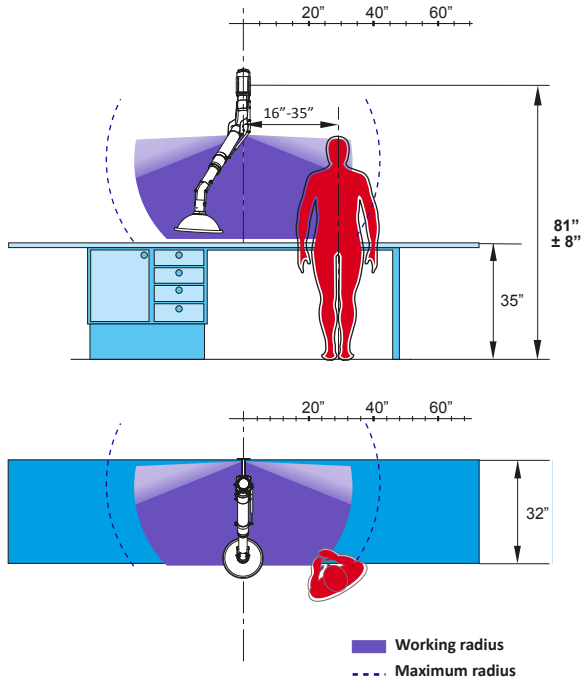

Range and recommended mounting height for MX 1500-75 and MX 1500-100

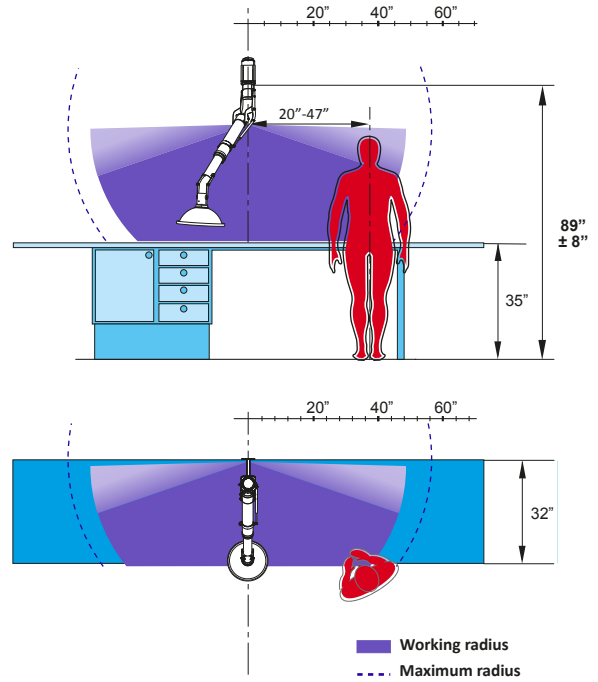

To optimize the usability of the extractor, the above mentioned mounting heights, and sideways displacements from the workplace, are recommended.

Applicable areas of use

Dimension	Activity
Ø 3 inch	Laboratories, Schools, Science Lecture Rooms
Ø 4 inch	Laboratories, Light Industry - Gluing - Solvents - Hard soldering - Light welding/TIG

Pressure drop diagram

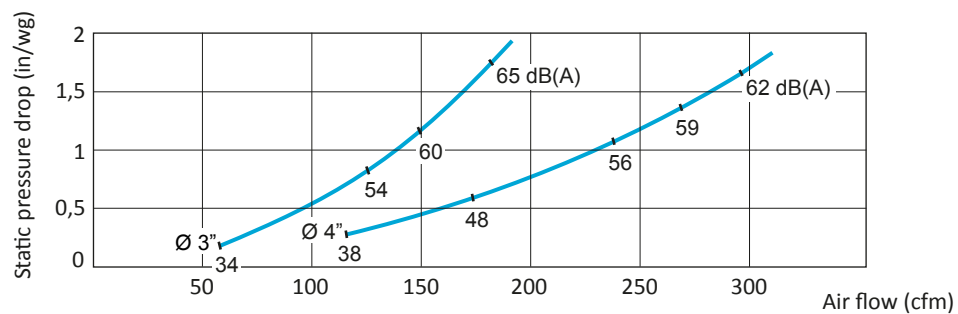

The static pressure drop is measured in accordance with ISO standard 5167-1. The noise level is measured according to ISO standard 3741.

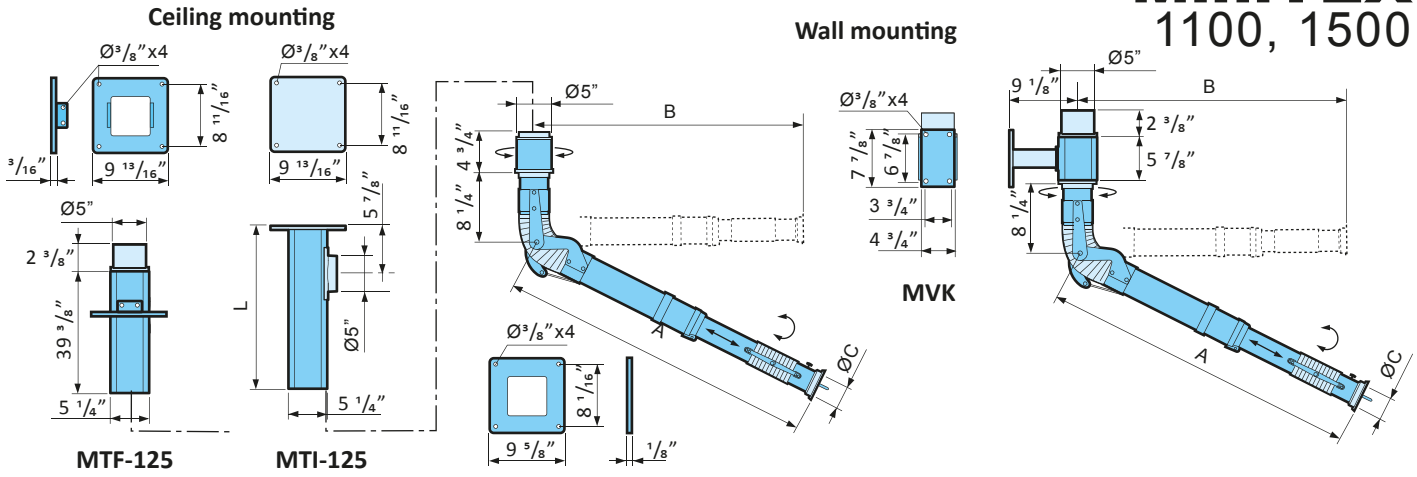

Ceiling mounting	L (in)	Weight (lb)
MTI 500-125	19 11/16	10 lb 13 oz
MTI 750-125	29 1/2	12 lb 12 oz
MTI 1000-125	39 3/8	14 lb 14 oz
MTI 1250-125	49 3/16	16 lb 14 oz
MTI 1500-125	59 1/16	18 lb 15 oz
MTI 1750-125	68 7/8	20 lb 15 oz
MTI 2000-125	78 3/4	22 lb 15 oz
Ceiling mounting	L (in)	Weight (lb)
MTF 1000-125	39 3/8	14 lb 5 oz

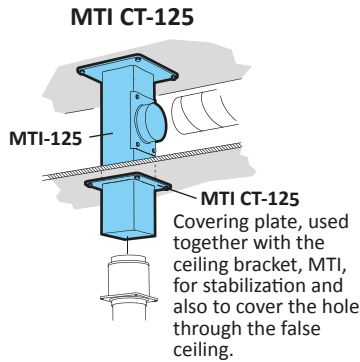

Designation	A (in)	B (in)	Ø C (in)	Weight (lb)
MXT 1100-75	43 5/16	31 1/2	3	10 lb 2 oz*
MXT 1500-75	59 1/16	39 3/8	3	11 lb 10 oz*
MXT 1100-100	43 5/16	31 1/2	4	12 lb 12 oz*
MXT 1500-100	59 1/16	39 3/8	4	14 lb 8 oz*

*weight excluding the bracket

Wall bracket	Weight (lb)
MVK-125	5 lb 8 oz

Hoods

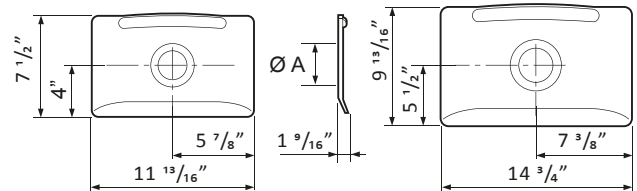
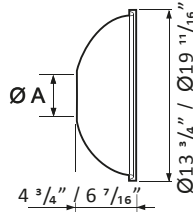
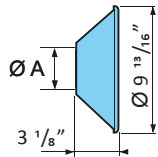

Metal hood

Designation	ØA (in)	Weight (oz)
MM 250	3	4.9
MM 251	4	4.9

The metal hood is used for work in tougher environments.. Capture of hot gases, dust spray, etc.

Dome hood

Designation	ØA (in)	Weight (oz)
MK 350	3	9.7
MK 351	4	9.7
MK 500	4	14.1

The dome hood is used to cover the source of contamination effectively, without blocking the line of sight. Available in Ø 13 3/4" for MiniTEX 75 and MiniTEX 100. For MiniTEX 100 is also a Ø 19 11/16" dome hood available.

Flat screen hood

Designation	ØA (in)	Weight (oz)
MPH 300	3	6.0
MPH 375	4	10.2

The flat screen hood is designed to maximise the working area without obscuring the object from the user. The flat screen hood provides the best suction power for work on tables and benches.

Materials

Ducts and profiles

Manufactured in thin-walled anodized aluminium.

Hose

Spring-steel coil completely enclosed in PVC coated polyamide fabric. Flame resistant, suitable for many chemicals.

Temperature range -22 °F to +212 °F.

For other qualities of hose, please contact Movex.

Metal components

Manufactured of powder-coated plate steel.

Plastic components

Manufactured of polypropylene.

Hoods

Hoods MK and MPH are manufactured in transparent PETG.

MM hoods are manufactured in coated aluminium.

Delivery description

The arm is supplied complete with an airtight damper.

Ceiling and wall mounting, brackets are ordered separately.

Metal-, dome- and flat screen hoods are available as accessories.